

## Data Receive Unit with up to 16 Bi-directional Data and Audio Channels plus Ethernet

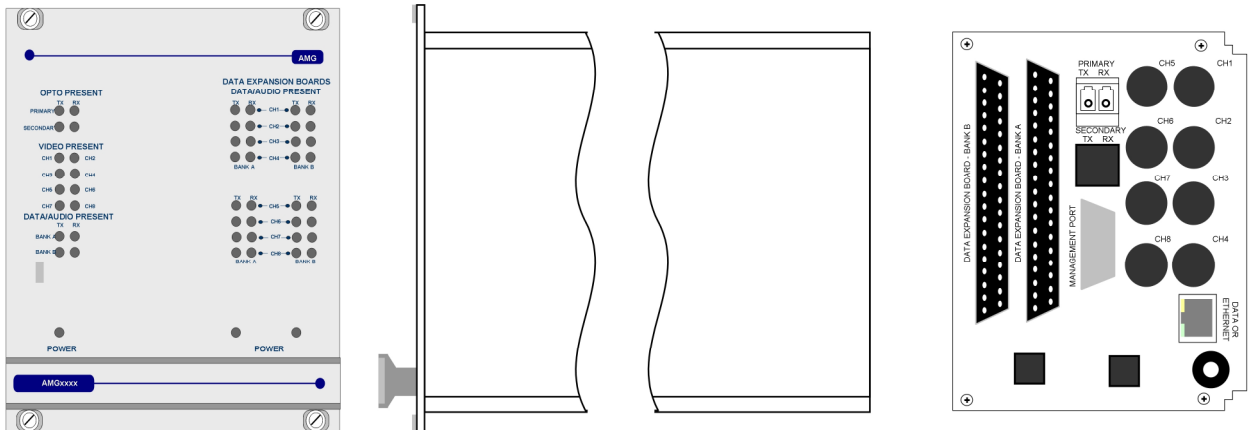

The **AMG4708EG** is a rackmount data receive unit designed to transmit and receive up to 16 data or audio signals plus full duplex 100BaseT Ethernet connectivity over two singlmode fibres. The 16 data/audio channel interfaces, whether RS232, RS422, RS485, 20mA, TTL, Contact Closure, Lonworks or Audio, are defined at manufacture by the addition of daughter boards fitted onto the Data Expansion Board Boards A and B.

The **AMG4708EG** is designed to plug into an AMG2005 subrack, which in turn fits into a 19" rack system. The rack incorporates an **AMG2003** power supply.

The **AMG4708EG** is designed to operate with **AMG4707E** or rackmount equivalent **AMG4707EG** data transmit unit in a point to point configuration.

# Contents

<b>Introduction</b>	<b>3</b>
Unit Functional Schematic.....	3
Optical Connection .....	3
<b>Connections</b>	<b>4</b>
Optical Connections .....	4
Power Connection .....	4
Ethernet Connection.....	4
Data Channel Connections.....	4
<b>Data and Audio Channel Configuration</b>	<b>5</b>
Data Interface Daughter Board Options .....	5
Data and Audio Channel Configuration.....	5
Daughter Board Layout .....	5
Data and Audio Daughter Board Fitting Instruction.....	5
Data and Audio Connections.....	6
<b>Front Panel Indicators</b>	<b>7</b>
Power LED.....	7
Fibre Optic LED's .....	7
Ethernet Data LED's.....	7
Low Speed Data LEDs .....	7
<b>Physical Information</b>	<b>9</b>
Dimensions .....	9
Mounting Details.....	9
Removal / replacement from / to the Case.....	9
<b>Safety</b>	<b>9</b>
<b>Maintenance and Repair</b>	<b>9</b>

## Introduction

### Unit Functional Schematic

The **AMG4708EG** receives up to 16 data and audio signals transmitted from the **AMG4707EG**.

It also transmits up to 16 data and audio channels to the **AMG4707EG**.

Ethernet connectivity is also provided between the two units.

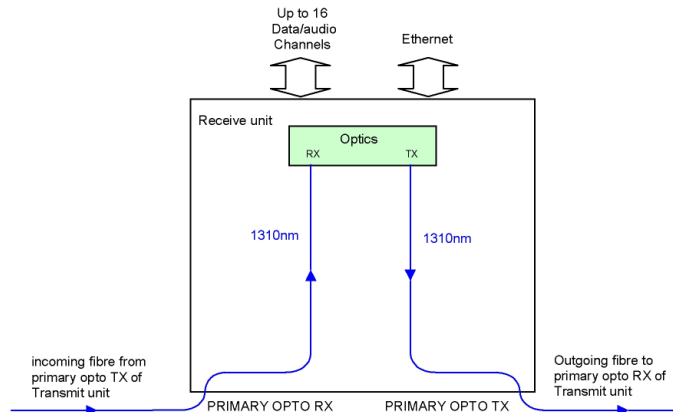

### Optical Connection

The **AMG4708EG** is connected as illustrated below when used with an **AMG4707EG** data transmit unit acting as a point to point system.

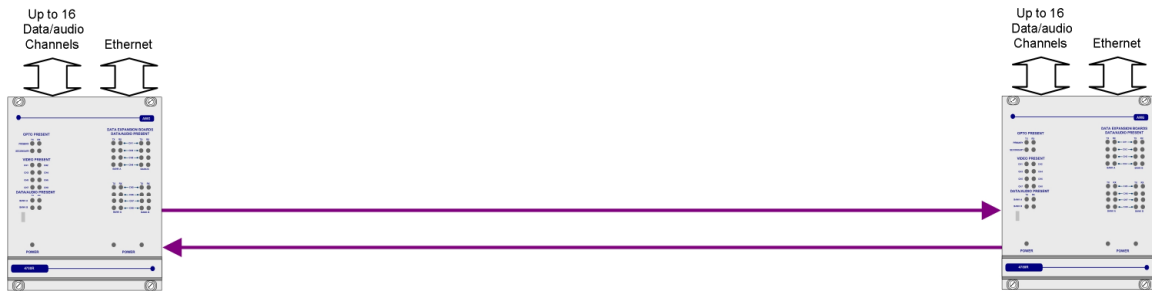

## **Connections**

---

### **Optical Connections**

#### **PRIMARY OPTO OUT**

Connector .....LC/PC  
Primary Optical Launch Power .....-5dBm  
Wavelength .....1310nm  
Optical Fibre .....Multimode

#### **PRIMARY OPTO IN**

Connector .....LC/PC  
Primary Optical Sensitivity .....-22dBm  
Wavelength .....1310nm  
Optical Fibre .....Multimode

### **Power Connection**

Connector Type .....2.1mm screw lock long power jack – centre positive  
Connector Partno.....Switchcraft S761K, AMG G16125-00  
Supply Voltage.....13.5 to 18.0 Volts DC.  
Maximum Power .....15 Watts

### **Ethernet Connection**

Ethernet Data Connector .....RJ45  
Interface .....Auto-negotiation up to 100BASE-TX full duplex  
Ethernet Data Rate .....Maximum 50Mbits/s total Ethernet traffic on fibre

### **Data Channel Connections**

Total No. of Data Channels .....16 channels  
  
Data/Audio Channels – BANK A .....8 channels  
Data/Audio Channels – BANK B .....8 channels  
Connectors .....Two 37-way D-Type female connectors - shielded.  
Connections .....See below for connection and configuration

For the data or audio channels to be present, the appropriate data daughter boards have to be fitted into the data expansion board slots.

## Data and Audio Channel Configuration

The **AMG4708E** and rackmount equivalent **AMG4708EG** sends and receives data in two banks - Bank A and Bank B each of which carries up to 8 channels of data / audio. The physical interface is determined by the fitting of AMG data or audio daughter boards onto the appropriate data expansion board slots.

### Data Interface Daughter Board Options

The data interface daughter board options are as follows:

Option Code 'x'	Part No.	Description
0	X12542	4 Wire Audio Interface Daughter Board
1	X04057	RS422/485 Data Interface Daughter Board
2	X04049	RS232 Data Interface Daughter Board
3	X04058	20mA Current Loop Data Interface Daughter Board
4	X12579	TTL Data Interface Daughter Board
5	X12578	Contact Closure Data Interface Daughter Board
6	X13038	FTT10A Echelon Lonworks Data Interface Daughter Board

### Data and Audio Channel Configuration

The data expansion board slots are accessed by removing the AMG unit from its case. A data channel is active when a daughter board is installed in the required data channel slot. Each data interface board enables one bi-directional channel.

### Daughter Board Layout

The channel slots are as follows:

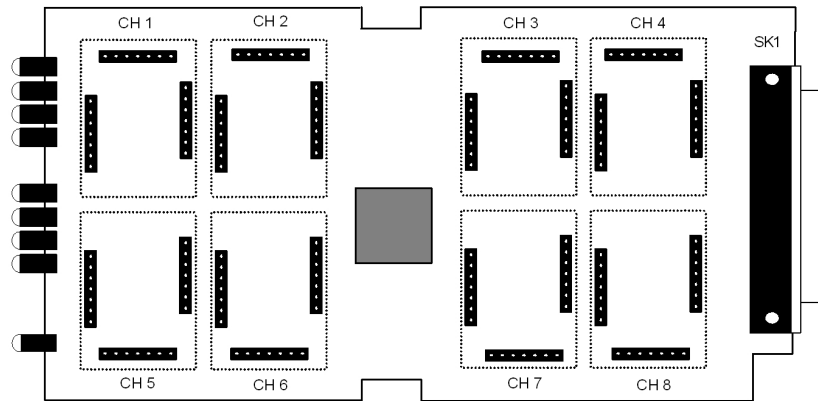

### Data and Audio Daughter Board Fitting Instruction

The data and audio daughter boards pushed on to the pin headers mounted on the data expansion boards. Ensure that the connectors are lined up correctly and not offset before pushing firmly in place. Note that the data and audio channel numbers are associated with each slot. This allocates the pin numbers on the rear panel connector together with the front panel LED indicators.

## Data and Audio Connections

The BANK A/B data/audio channels pin connections on the rear panel connectors are as follows:

Pin No.	Description	Bank
1	Audio/Data CH1 IN + (A)	A/B
2	Audio/Data CH1 IN - (B)	A/B
3	Audio/Data CH2 IN + (A)	A/B
4	Audio/Data CH2 IN - (B)	A/B
5	Audio/Data CH3 IN + (A)	A/B
6	Audio/Data CH3 IN - (B)	A/B
7	Audio/Data CH4 IN + (A)	A/B
8	Audio/Data CH4 IN - (B)	A/B
9	GND	A/B
10	GND	A/B
11	GND	A/B
12	Audio/Data CH5 IN + (A)	A/B
13	Audio/Data CH5 IN - (B)	A/B
14	Audio/Data CH6 IN + (A)	A/B
15	Audio/Data CH6 IN - (B)	A/B
16	Audio/Data CH7 IN + (A)	A/B
17	Audio/Data CH7 IN - (B)	A/B
18	Audio/Data CH8 IN + (A)	A/B
19	Audio/Data CH8 IN - (B)	A/B

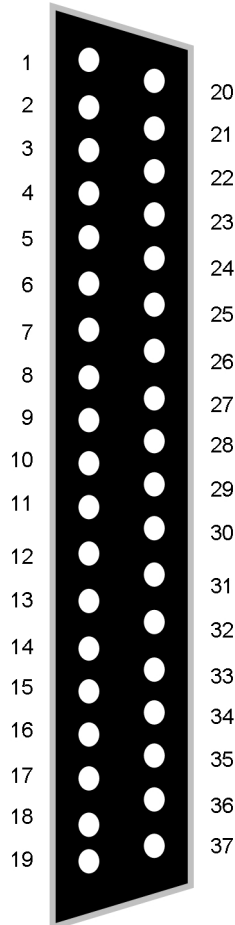

Pin No.	Description	Bank
20	Audio/Data CH1 OUT + (A)	A/B
21	Audio/Data CH1 OUT - (B)	A/B
22	Audio/Data CH2 OUT + (A)	A/B
23	Audio/Data CH2 OUT - (B)	A/B
24	Audio/Data CH3 OUT + (A)	A/B
25	Audio/Data CH3 OUT - (B)	A/B
26	Audio/Data CH4 OUT + (A)	A/B
27	Audio/Data CH4 OUT - (B)	A/B
28	GND	A/B
29	GND	A/B
30	Audio/Data CH5 OUT + (A)	A/B
31	Audio/Data CH5 OUT - (B)	A/B
32	Audio/Data CH6 OUT + (A)	A/B
33	Audio/Data CH6 OUT - (B)	A/B
34	Audio/Data CH7 OUT + (A)	A/B
35	Audio/Data CH7 OUT - (B)	A/B
36	Audio/Data CH8 OUT + (A)	A/B
37	Audio/Data CH8 OUT - (B)	A/B

Note: (A) or (B) in brackets in above table refers to RS485/RS422 data specification not Bank A, B.

See Data or Audio Daughter Board Instruction Sheet for meaning of Audio/Data IN+, Audio/Data IN-, Audio/Data OUT+, and Audio/Data OUT- for each data type.

## Front Panel Indicators

---

### Power LED

Power .....	Green	-	unit powered
	Off	-	no power applied to unit

### Fibre Optic LED's

Primary Opto Sync TX.....	Green	-	optical channel transmitting
	Off	-	optical channel not transmitting
Primary Opto Sync RX .....	Green	-	optical channel receiving
	Org	-	optical channel receiving but not sync.
	Off	-	optical channel not transmitting

### Ethernet Data LED's

#### BANK A

Data Present TX (Ethernet).....	Green	-	data present on the Ethernet input
	Off	-	no data present on the Ethernet input

This represents the Ethernet signals being transmitted onto the optical fibre

Data Present RX (Ethernet) .....	Green	-	data present on the Ethernet input
	Off	-	no data present on the Ethernet input

This represents the Ethernet signals being received from the optical fibre

#### BANK B

Data Present TX .....	Green	-	RJ45 Ethernet port operating at 100Mbit/s
	Red	-	RJ45 Ethernet port operating at 10Mbit/s

Data Present RX.....	Green	-	RJ45 Ethernet port operating full duplex
	Off	-	RJ45 Ethernet port operating half duplex

Note: the RJ45 Ethernet auto-negotiates up to 50Mbit/s full duplex.

### Low Speed Data LEDs

#### BANK A or B (When RS232 data daughter board fitted)

Data Present CH1-16 TX .....	Green	-	logic zero (+V) present on IN+
	Red	-	logic transitions present on IN+
	Off	-	logic one (-V) present on IN+

This represents the data signals being transmitted on the optical fibre

Data Present CH1-16 RX .....	Green	-	logic zero (+V) present on OUT+
	Red	-	logic transitions present on OUT+
	Off	-	logic one (-V) present on OUT+

This represents the data signals being received on the optical fibre

#### BANK A or B (When RS485 / RS422 data daughter board fitted)

Data Present CH1-16 TX .....	Green	-	logic zero (+V, -V) present on IN+, IN-
	Red	-	logic transitions present on IN+, IN-
	Off	-	logic one (-V, +V) present on IN+, IN-

This represents the data signals being transmitted on the optical fibre

Data Present CH1-16 RX .....	Green	-	logic zero (+V, -V) present on OUT+, OUT-
	Red	-	logic transitions present on OUT+, OUT-
	Off	-	logic one (-V , +V) present on OUT+, OUT-

This represents the data signals being received on the optical fibre

**BANK A or B** (When audio daughter board fitted)

Audio Present TX.....	Green	-	audio present > -40dBm
	Red	-	audio present > 0dBm (overload at +6dBm)
	Off	-	audio not present or < -40dBm

This represents the data signals being transmitted on the optical fibre

Audio Present RX .....	Green	-	audio present > -40dBm
	Red	-	audio present > 0dBm (overload at +6dBm)
	Off	-	audio not present or < -40dBm

This represents the audio signals being received from the optical fibre.



## **Physical Information**

---

### **Dimensions**

Height ..... 3U Plug-in  
Width ..... 21HP  
Depth ..... 170mm excluding connectors  
Weight ..... 1200grams

### **Mounting Details**

The unit is designed to be mounted within an AMG2009 or AMG2015 Subrack on standard card guides.

### **Removal / replacement from / to the Case**

Note: - The AMG unit PCB's are static sensitive. Handle with proper care and use normal electrostatic discharge (ESD) procedures. Use properly grounded protection (for example, wrist straps) when handling the PCB.

To remove units from the case to access the data expansion boards and the daughter boards, remove the 2 or 4 fixing screws on the rear panel and slide the PCB's out of the case. Ensure that the fibres do not snag or get trapped.

To replace the PCB's into the case, slide the PCB's gently into the case aligning the boards with the appropriate slots. Ensure that the fibre do not snag or get trapped.

## **Safety**

---

AMG Optical Fibre Products use Class 1 laser systems in accordance with EN 60825-2:2000.

It is always advisable to follow good practice when working with optical fibre systems. This includes:

- Do not stare with unprotected eyes or with any unapproved collimating device at fibre ends or connector faces, or point them at other people.
- Use only approved filtered or attenuating viewing aids

For other safety issues and advice on good practice associated with optical fibre systems, please see EN 60825-2:2000 or your local safety officer.

## **Maintenance and Repair**

---

There are no user serviceable parts within AMG products. See unit data sheet for full specification.

In case of problem or failure, please call your local support centre or contact: **AMG Systems Ltd.** at 3 The Omega Centre, Stratton Business Park, Biggleswade, Beds., SG18 8QB, UK.

Phone	+44 (0) 1767 600 777
Technical Support	+44 (0) 1767 604 491
Email	techsupport@amgsystems.com

This page is intentionally blank.

This page is intentionally blank.

This page is intentionally blank.